

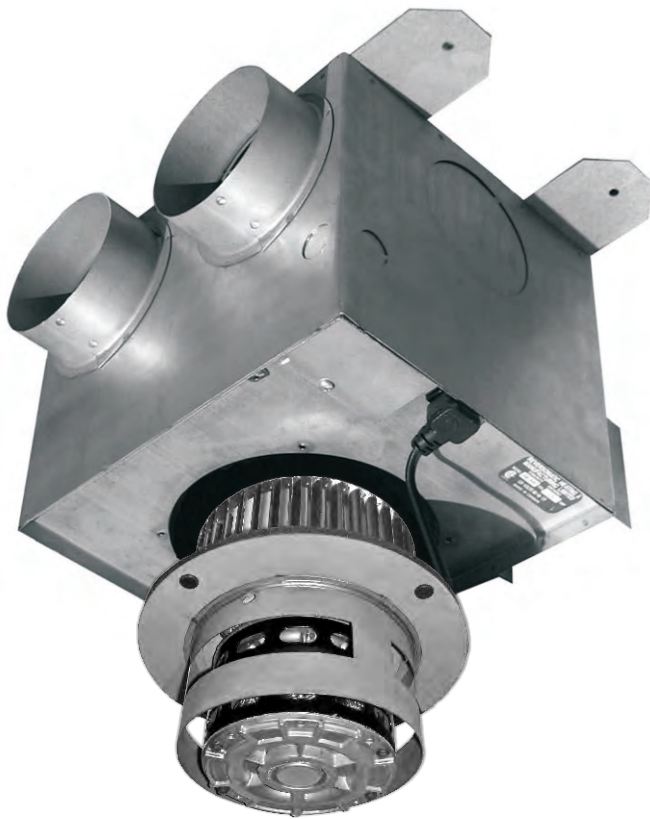

XL SERIES EXHAUST FAN FOR BATHROOMS

The DB-300, QDB-300 fans are especially designed to exhaust air from a combination of bathrooms. They are equipped with squirrel cage impeller. The QDB-300 has a low speed motor for quiet function.



DB-300 FAN DATA

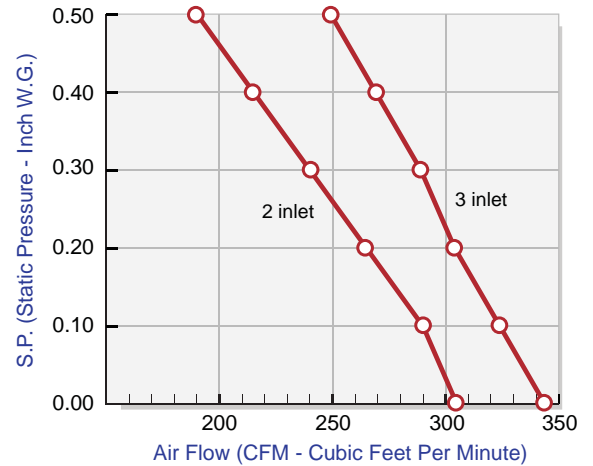

QDB-300 FAN DATA

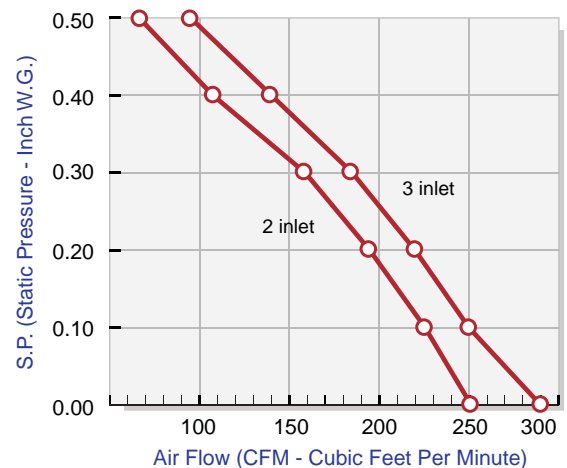

ACCESSORIES

Standard

- Neoprene Damper
- Mounting brackets

Optional

- Balance Box
- Transition
- Speed Controller
- Aluminum Backdraft Damper



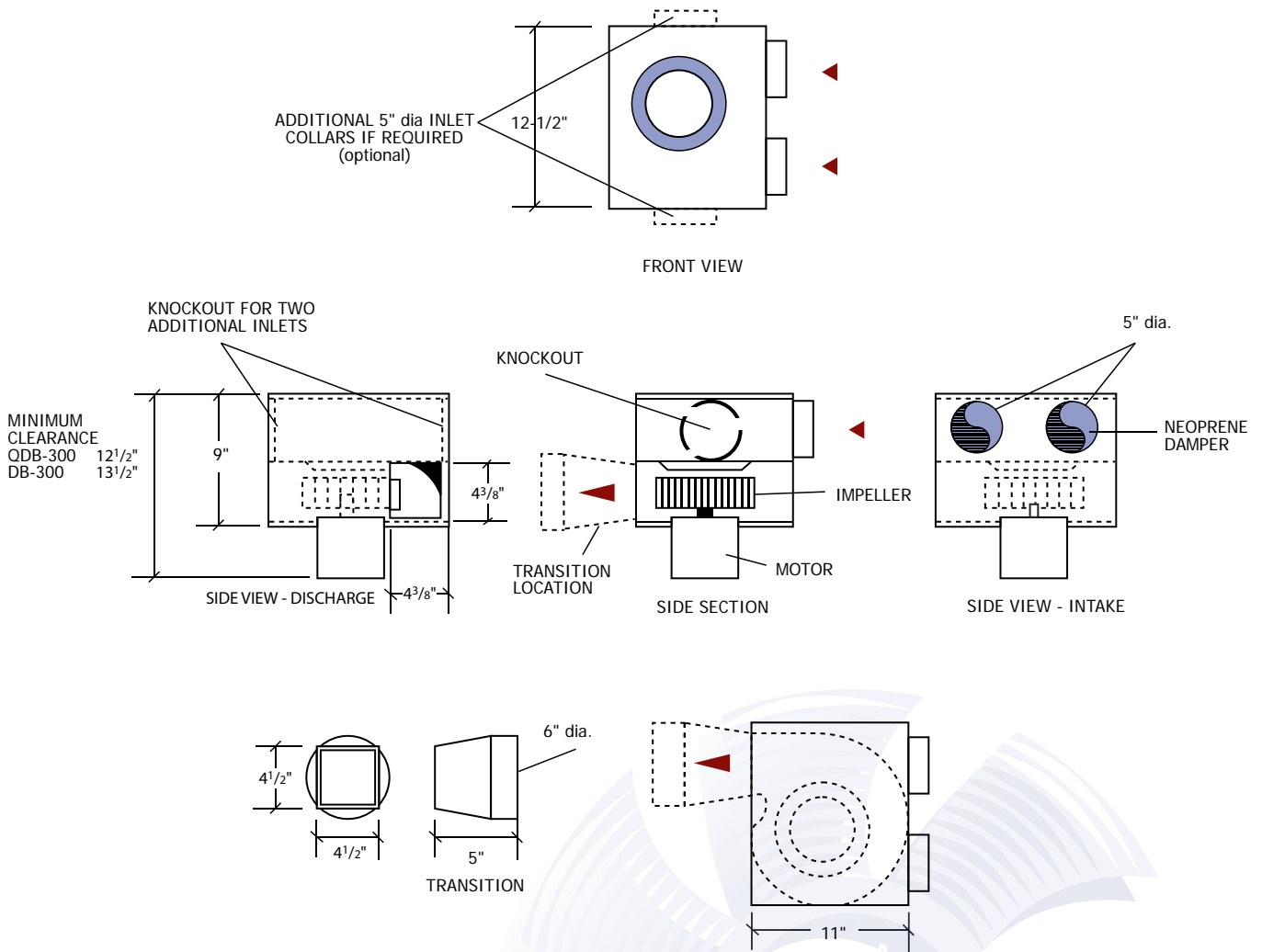

FAN DATA

MODEL	MOTOR 120VAC 60Hz		CUBIC FEET PER MINUTE						
	RPM	AMPS	S.P.	0.00	0.10	0.20	0.30	0.40	0.50
DB-300	1550	3.3	CFM 2 inlets	305	290	265	240	215	190
			CFM 3 inlets	345	325	305	290	270	250
QDB-300	1050	3.0	CFM 2 inlets	250	225	195	160	110	70
			CFM 3 inlets	290	250	220	185	140	95

RPM (Revolution Per Minute) shown is nominal and performance is based on actual speed of test.

Contractor:		DB-300, QDB-300		
Architect:	Job:	Date	Supersedes	Drawing NO.
Engineer:	Date Submitted:			

Reversomatic Manufacturing Ltd.

790 Rowntree Dairy Road, Woodbridge, ON Canada L4L 5V3 • Tel: 905-851-6701 • Fax: 905-851-8376
 www.reversomatic.com • info@reversomatic.com