

INSTALLATION AND WIRING INSTRUCTIONS

For Pluggable Motor Replacement



⚠ WARNING

Electrical Shock Hazard

Disconnect power before servicing.
Failure to do so can result in death or electrical shock.

This Kit Contains:

- 1 Motor Assembly
- 2 1/8" Female Terminals (Insulated)
- 1 Sheet, Instruction

NOTE TO THE INSTALLER: This motor kit is an authorized FSP service replacement part for your application. The motor in this kit may or may not be identical to your old motor. If your current motor has the pluggable motor switch (see Figure 4B), replace the service motor in the same manner as you removed your failed motor. If your failed motor has the switch where the wire lead from the main harness connects to the motor switch individually, carefully follow instructions below.

⚠ WARNING



Fire Hazard

Do not under any circumstances attempt to remove or replace the motor switch from this pluggable service motor. The switch is a non-serviceable component.

Failure to do so can result in death, serious injury, or fire.

1. Remove failed motor using standard motor removal procedures.
2. Compare and note the difference between the failed motor and your new replacement motor. The first thing you will need to compare is the motor pulleys. The pulley supplied with the replacement motor can be used in most applications. If your dryer has a 6-rib belt that is too large to fit onto the pulley on your new replacement motor, you must either replace the belt with part number 341241 or remove the pulley from the failed motor and mount it to the new service motor. There are also two (2) other cases you may want to use the pulley from the failed motor. See Figure 1 for these two (2) cases.



3-SPEED
APPLICATION
PART NO. 345472



2-SPEED
APPLICATION
PART NO. 687076

FIGURE 1

NOTE: if you choose not to reuse your pulley from the failed motor as shown in Figure 1, you will lose the 2-speed or 3-speed option.

© Whirlpool Corporation 1996
(All Rights Reserved)

3. If you choose to use the pulley supplied with the replacement motor, you may proceed to step 8. Otherwise proceed to step 4.
4. Remove pulley from replacement motor by using two (2) open end or adjustable wrenches. Place one on the motor shaft, right behind the pulley, and the other on the pulley. Holding the motor shaft in place with one (1) wrench, turn pulley with other wrench in a counterclockwise direction to remove pulley. See Figure 2.
5. Remove belt restrainer from failed motor, if used. See Figure 2.

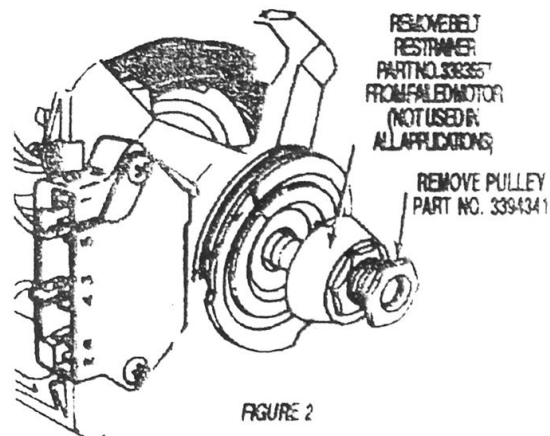

FIGURE 2

- From the switch end of the replacement motor, cut the threaded portion of the motor shaft off using a hacksaw. See Figure 3.

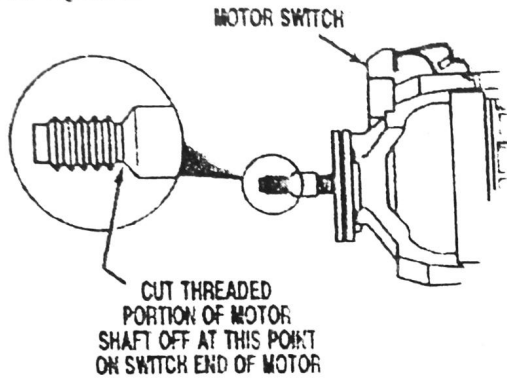

FIGURE 3

NOTE: DO NOT cut the threaded portion off of the motor shaft if your pulley screws off of the failed motor.

- With an allen wrench, remove the pulley from the failed motor and reinstall it on the replacement motor. Be sure to push pulley onto the motor shaft all the way and tighten the setscrew securely in place.

- Compare and note difference between the motor switch of the failed motor and the switch of the new replacement motor. If the switches are the same, simply install the motor in reverse order you've removed the failed motor. See Figures 4A & 4B. If not, proceed to step 9.

NOTE: Overload protector is part of the pluggable switch on the replacement motor and separate on the old motor switch.

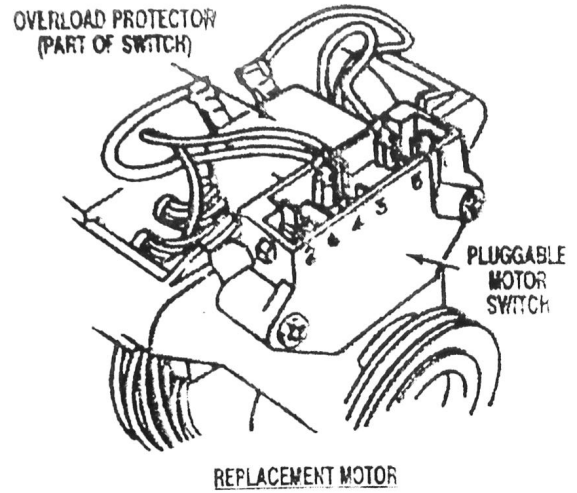

FIGURE 4B

- Position motor as shown in Figure 5. Note the location of the motor switch. Secure motor to bracket with the original motor clamps.

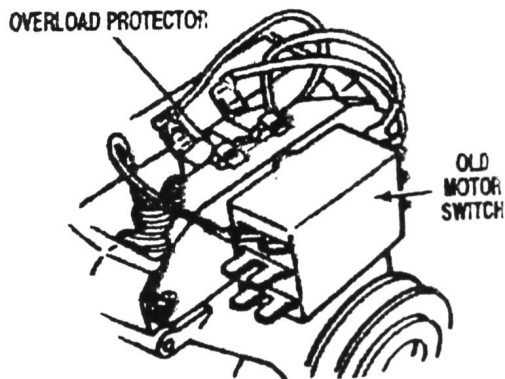

FIGURE 4A

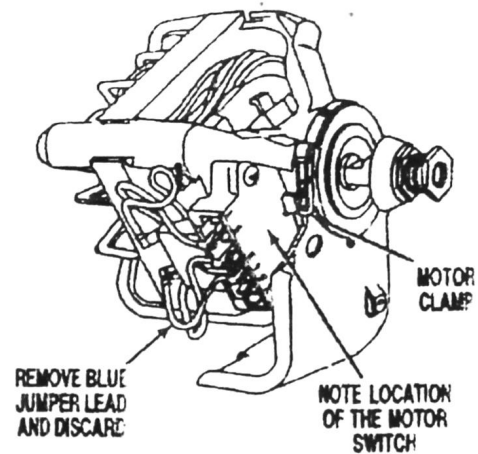

FIGURE 5

WIRING INSTRUCTIONS

10. Disconnect and remove the blue jumper wire that runs from the motor switch to the overload and discard. See *Figure 5*.
11. Connect the blue (4M) wire from main harness to the vacant terminal on the overload protector that you remove the jumper wire from in step 10. See *Figure 6*.
12. Connect the red (1M) wire lead from main harness to the 1/4" terminal marked 1 on the motor switch. See *Figure 6*.
13. Connect the red (2M) wire lead from main harness to the 1/4" terminal marked 2 on the motor switch. See *Figure 6*.
14. To connect the black (6M) wire lead from main harness and the white (5M) wire lead from main harness to the motor switch, you must replace the 1/4" female terminals with the 1/8" insulated female terminals included with the replacement motor.

NOTE: If your unit does not have a black (6M) wire lead, disregard any instructions referring to the black (6M) wire.

15. Cut the 1/4" female terminal from the black (6M) and white (5M) wire leads from main harness as close to the terminal as possible with wire cutters.
16. Strip wires back approximately 1/4 of an inch.
17. With barrel crimpers, crimp 1/8" insulated female terminals, included with motor, onto the wire leads.
NOTE: Make sure terminals are crimped securely in place.
18. Connect the white (5M) wire lead from main harness onto the 1/8" terminal marked 5 on the motor switch. See *Figure 6*.
19. Connect the black (6M) wire lead from main harness onto the 1/8" terminal marked 6 on the motor switch. See *Figure 6*.

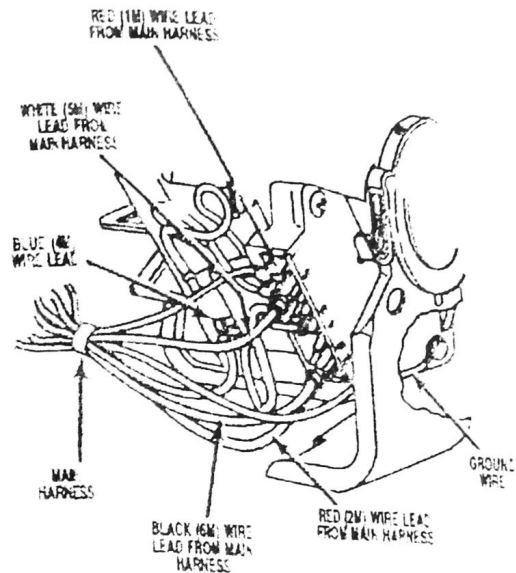

FIGURE 6

20. Reconnect ground wire. See *Figure 6*.
21. All wire lead connections are complete at this point. Finish reassembling dryer.